

## PERFORMANCE DATA SHEET NEMA PREMIUM NR CAN NEMA 12 - 12

Catalogue #: MPOP-8

HP	kW	Voltage	S.F. @ 60Hz	EFF.	P.F.	Frame	Design	L.R. Amps
1.5	1.12	575	1.15	86.5%	0.68	182T	B	16

60 Hz								
FLA							Code	F.L. RPM
208	230	416	460	480	575	600		
/	/	/	/	/	1.9	1.82	M	1175

50 Hz								
FLA			S.F. @ 50Hz	Efficiency	Power Factor	Code	F.L. RPM	
190	380	415						
/	/	/	/	/	/	/	/	

Wgt. Lbs	PH	Duty	Insul. Class	Amb.	Elevation	Temp. Rise° C
95	3	Cont.	F	40°C	1000M (3300 Ft)	< 80

% Efficiency		% Power Factor		Torque		Winding Resist. Ω	Safe Cold Start (Secs)
Full Load:	86.5%	Full Load:	0.68	Full Load Ft/Lbs	6.7		
3/4 Load:	85.0%	3/4 Load:	0.59	Locked Rotor %	220		
1/2 Load:	83.0%	1/2 Load:	0.47	Break Down %	290		

Rotor Inertia Wk2 Lb-Ft2	Max Load Inertia Wk2 Lb-Ft2	Shaft Material	Frame Material	DE Bracket Type	ODE Bracket Type	Enclosure	NEMA Rating	Lead Wire Size
0.24	32	Standard	Rolled Steel	Standard	Standard	ODP	IP23	16AWG

Ball Bearings		Grease	Mount Type	Orientation	Paint	Sound Pressure @ 3FT	Sound Power
DE	ODE						
6206	6206	Sealed Bearings	Rigid	Horizontal	Green	57	67

Inverter Duty. Motor meets MG1 parts 31.4.4.2	Constant Torque Range	Variable Torque Range	Constant HP RPM
	10:1	20:1	1800

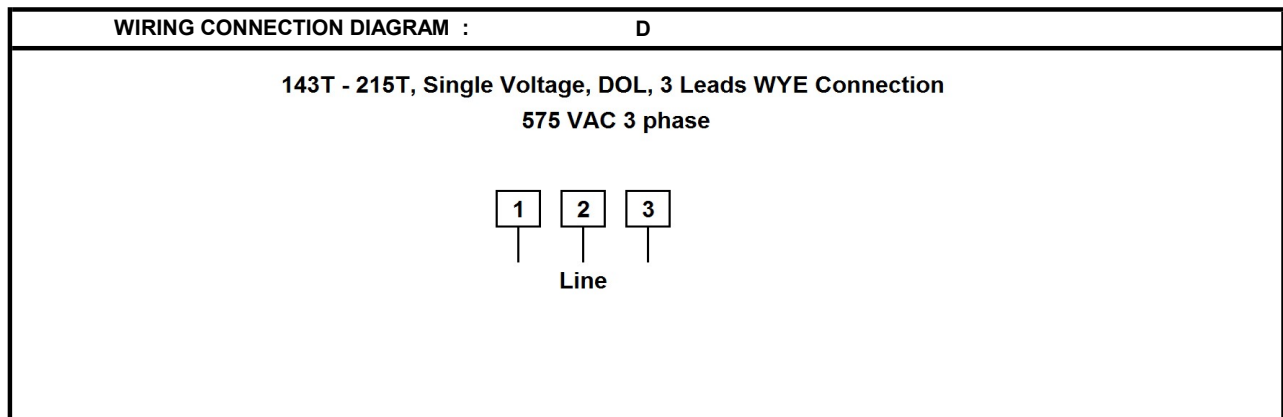

Date: 2020-02-17  
 Customer: \_\_\_\_\_  
 Contact: \_\_\_\_\_  
 Submittee: J.C. Lavallée

Catalogue #: **MPOP-8**

NEMA PREMIUM NR CAN NEMA 12 - 12										
HP	VAC	RPM	Enclosure	Frame	Frequency	Design	Poles	LR Code Letter	Insulation Class	Temp. Rise °C
1.5	575	1175	ODP	182T	60	B	6	M	F	< 80
	0Hz	6Hz	15Hz	30Hz	45Hz	60Hz	75Hz	90Hz	105Hz	120Hz
Amps	1.9	1.9	1.9	1.9	1.9	1.9	1.9	1.9	1.9	1.9
RPM	0	117.5	293.75	587.5	881.25	1175	1468.75	1762.5	2056.25	2350
Torq ft.lb	5.36	6.70	6.70	6.70	6.70	6.70	5.36	4.47	3.83	3.35
Peak Tq ft.lb	8.21	16.43	16.43	16.43	16.43	16.43	13.14	10.95	9.39	8.21
HP	0	0.2	0.4	0.8	1.1	1.5	1.5	1.5	1.5	1.5
	Locked Rotor	Pull-Up	Breakdown	Rated Load	Idle	Duty	S. F.	Ambient	Elevation	dBA @ 1M
Speed (RPM)	0.0	504	960	1175	1200	Continuous	1.15	40°C	3300 ft	57
Current (Amps)	16.0	13.6	9.5	1.9	0.9	VFD Rating: Meets MG1 parts 31.4.4.2				
Torque (ft-lbs)	14.8	11.1	19.4	6.7	0.0	C.T.	10:1	V.T.	20:1	

Motor Speed Data

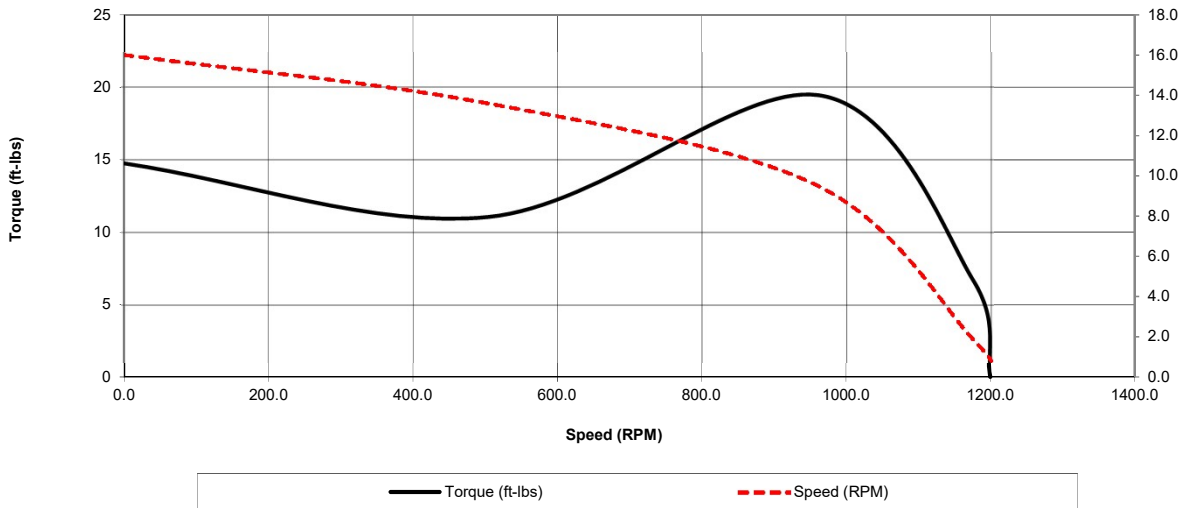

Motor Torque Capability vs RPM

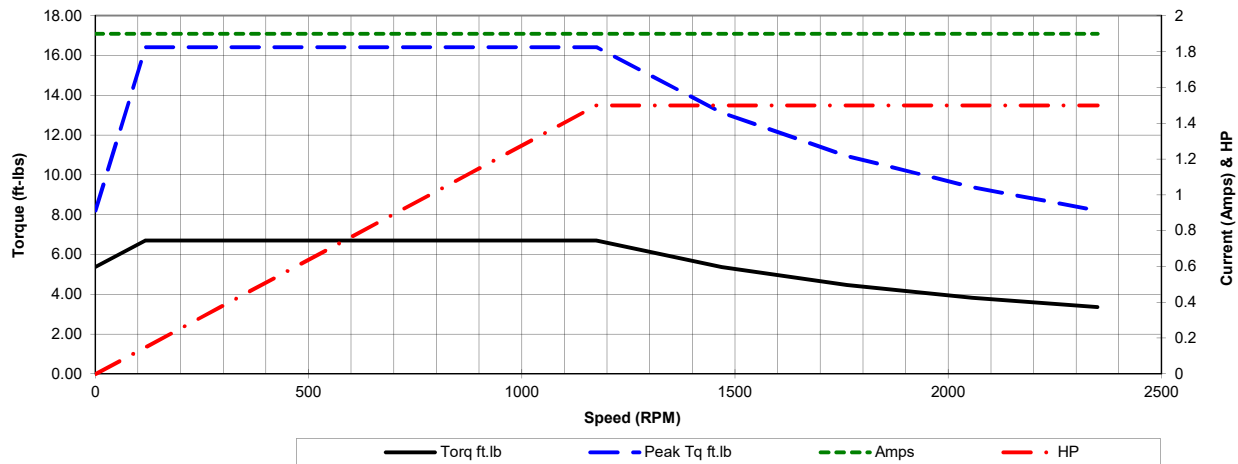



Date: 2020-02-17  
 Customer: \_\_\_\_\_  
 Contact: \_\_\_\_\_  
 Submittee: J.C. Lavallée

Catalogue #: **MPOP-8**

NEMA PREMIUM NR CAN NEMA 12 - 12										
HP	VAC	RPM	Enclosure	Frame	Frequency	Design	Poles	LR Code Letter	Insulation Class	Temp. Rise °C
1.5	575	1175	ODP	182T	60	B	6	M	F	< 80
Load %	0%	25%	50%	75%	100%	125%	150%			
Amps	0.86	0.89	1.16	1.50	1.90	2.39	2.73			
Torq ft/lbs	0	1.65	3.32	5.00	6.70	8.43	10.17			
RPM	0	1193.75	1187.5	1181.25	1175	1168.75	1162.5			
Eff	0	79.03	83.00	85.00	86.50	86.50	86.50			
PF	0	40	47	59	68	68	71.4			
	Locked Rotor	Pull-Up	Breakdown	Rated Load	Idle	Duty	S. F.	Ambient	Elevation	dBa @ 1M
Speed (RPM)	0	504	960	1175	1200	Continuous	1.15	40°C	3300 ft	57
Current (Amps)	16	13.6	9.5	1.9	0.855	VFD Rating: Meets MG1 parts 31.4.4.2				
Torque (ft-lbs)	14.75	11.06	19.44	6.70	0.0	C.T.	10:1	V.T.	20:1	

Motor Speed Data

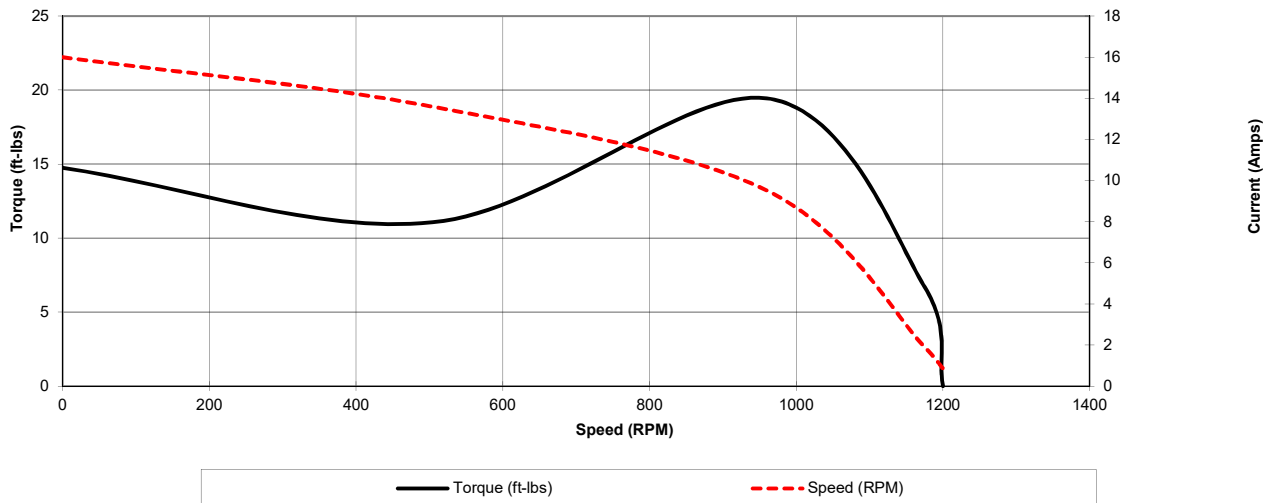

Motor Load Data

